

Powers™ Controls

SW 141 Differential Static Airflow Switches



141-0518

Description

The SW 141 Airflow Switch senses static differential pressure and the diaphragm operated snap switches actuate electrical circuits. Auto reset and manual reset models are available.

Application

Auto reset switches (141-0518 and 141-0574) should be used for applications requiring positive proof of airflow (or fan operation) or to detect high differential pressures associated with dirty air filters or similar maintenance alarms not requiring safety lock-out (shut down) of the fan.

The manual reset switch (141-0575) should be used for applications requiring safety lock out (shut down) of the fan. The switch can be used on the fan discharge (positive pressure), fan inlet (negative pressure), or across the fan (differential pressure) to detect excessively high positive pressures or low negative pressures, and turn off the fan before damage occurs to ducts or dampers.

Product Numbers

Table 1.

Product Number	Setpoint Range (Field Adjustable)	Setpoint * Accuracy	Switching * Differential	Switching Action
141-0518	1" to 12" WC (250 Pa to 3000 Pa)	@ 12" ± 1.5" WC (3000 Pa ± 375 Pa)	Approx. 0.6" to 1.5" WC (150 Pa to 375 Pa)	SPDT/ Auto Reset
141-0575	1" to 12" WC (250 Pa to 3000 Pa)	@ 12" ± 1.5" WC (3000 Pa ± 375 Pa)	Not Applicable	SPST/ Manual Reset
141-0574	0.05" to 2.0" WC (12.5 Pa to 498 Pa)	@ 2" ± 0.2" WC (498 Pa ± 50 Pa)	Approx. 0.06" to 0.6" WC (15 Pa to 150 Pa)	SPDT/ Auto Reset

* Setpoint accuracy **tolerance** and switching differential decrease proportional to setpoint decrease.

Specifications	Measured media	Air
	Switch action	
	Auto reset	See Table 1
	Manual reset	Switch is Normally Closed (N.C.) and only opens on increasing pressure signal. Switch must be manually reset by operator
Operating	Ambient temperature range	-40°F to 180°F (-40°C to 82°C)
	Maximum overpressure	0.5 psi (3.4 kPa)
	Mounting position	Diaphragm in any vertical plane
	Physical	Electrical ratings
Physical	Conduit opening	One, conduit size 1/2-inch
	Sample line connectors	Two connectors, complete with nuts and ferrules, which accept 1/4-inch OD (6.4 mm) copper or poly tubing
	Material	Aluminized steel
	Agency certification	
	U.L.	MFHX File MH9888
	CSA	1811M25
	Weight	1 lb (0.45 kg)
Dimensions	See Figure 9	
Accessories	High accuracy static pressure sensor	269-062
	Static pressure sensing kit	189-142

Operation The diaphragm operates a spring lever to actuate the snap switch. The manual reset switch keeps the electrical contact open until pushed to reset. Turning the adjustment knob clockwise increases the setpoint.

Installation Mount the unit with the diaphragm in any vertical plane. Connect the static pressure line(s) as shown in Figure 1.

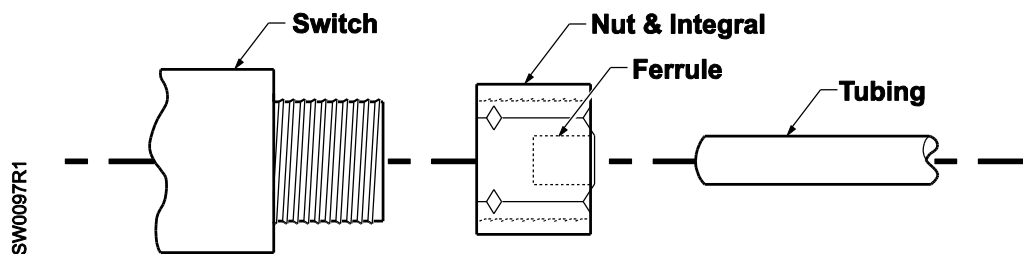

Figure 1. Connecting the Static Pressure Line.

Installation, Continued

For use as a negative pressure switch:

Connect the static pressure line to the low inlet (marked on the case and Figure 2) and leave the high inlet open to the atmosphere.

For use as a positive pressure switch:

Connect the static pressure line to the high inlet (marked on the case and Figure 2) and leave the low inlet open to the atmosphere.

For use as a differential pressure switch:

Connect the highest static pressure line to the high inlet and the lowest static pressure line to the low inlet (marked on the case and Figure 2.)

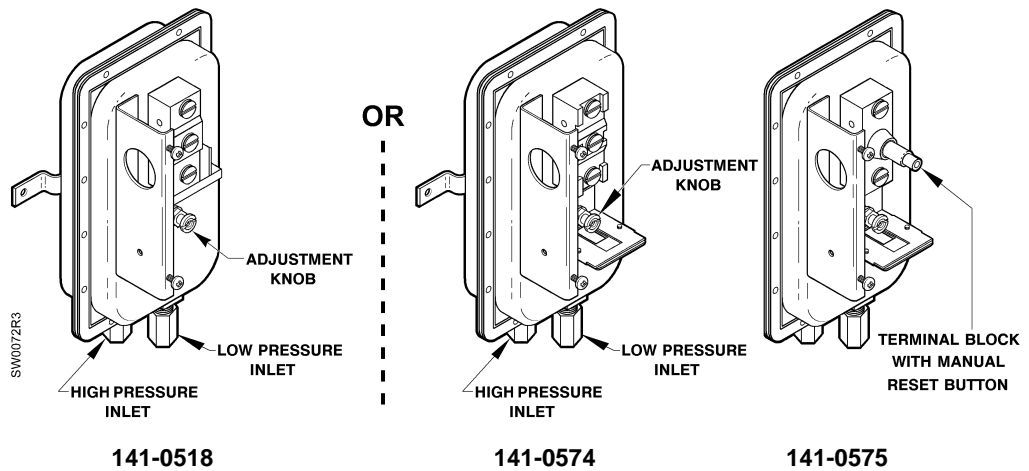

Figure 2. Switches with Covers Removed.

Setpoint Adjustment

Each switch is factory set at the minimum setpoint. See Table 1.

1. To increase the setpoint, turn the adjustment screw clockwise as shown in Figure 2 and Figure 3. From the lowest setpoint, several turns are necessary to engage the adjusting mechanism.
2. Adjust the setpoint until switching occurs at the required point.
3. Check the setpoint for accuracy with a magnahelic gauge.

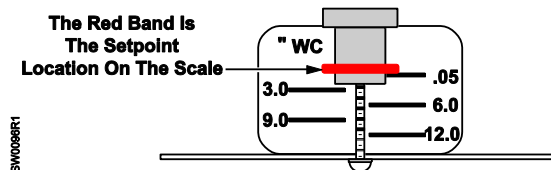

Figure 3. Adjusting the Setpoint.

Pressure Sensors

Pressure sensor selection is based on the medium to be measured, the measurement type (static or velocity), and the required range and accuracy.

Pressure sensors measure the difference between two sensing ports usually labeled high and low. This provides a pressure measurement against a reference. Measuring the pressure inside a pipe or duct and comparing it to the air outside (ambient) the pipe or duct is an example of static pressure measurement. A sensor measuring the pressure differential across a pump or chiller measures velocity pressure.

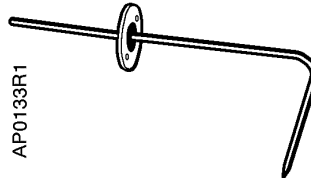

Figure 4. Pitot Tube (Part Number 269-062).

Wiring Diagrams

Before setpoint pressure is applied to the diaphragm, the switch contact is in a normally closed position as shown in Figures 5 and 6.

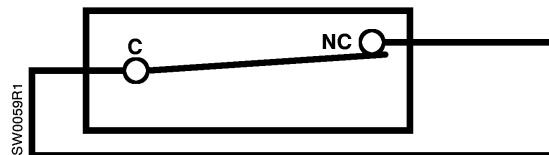

Figure 5. Manual Reset Switch 141-0575.

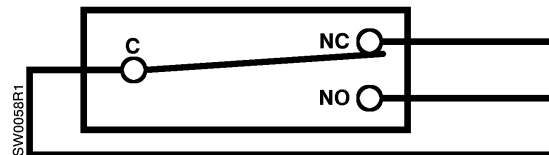

Figure 6. Auto Reset Switches 141-0518 and 141-0574.

SPDT terminals are marked Common (C), Normally Open (NO), and Normally Closed (NC).

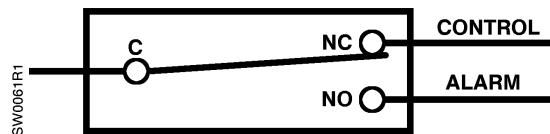

Figure 7. Auto Reset Switches to Prove Excessive Airflow or Pressure.

**Wiring Diagrams,
 Continued**

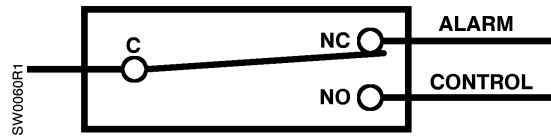

Figure 8. Auto Reset Switches to Prove Insufficient Airflow or Pressure.

Dimensions

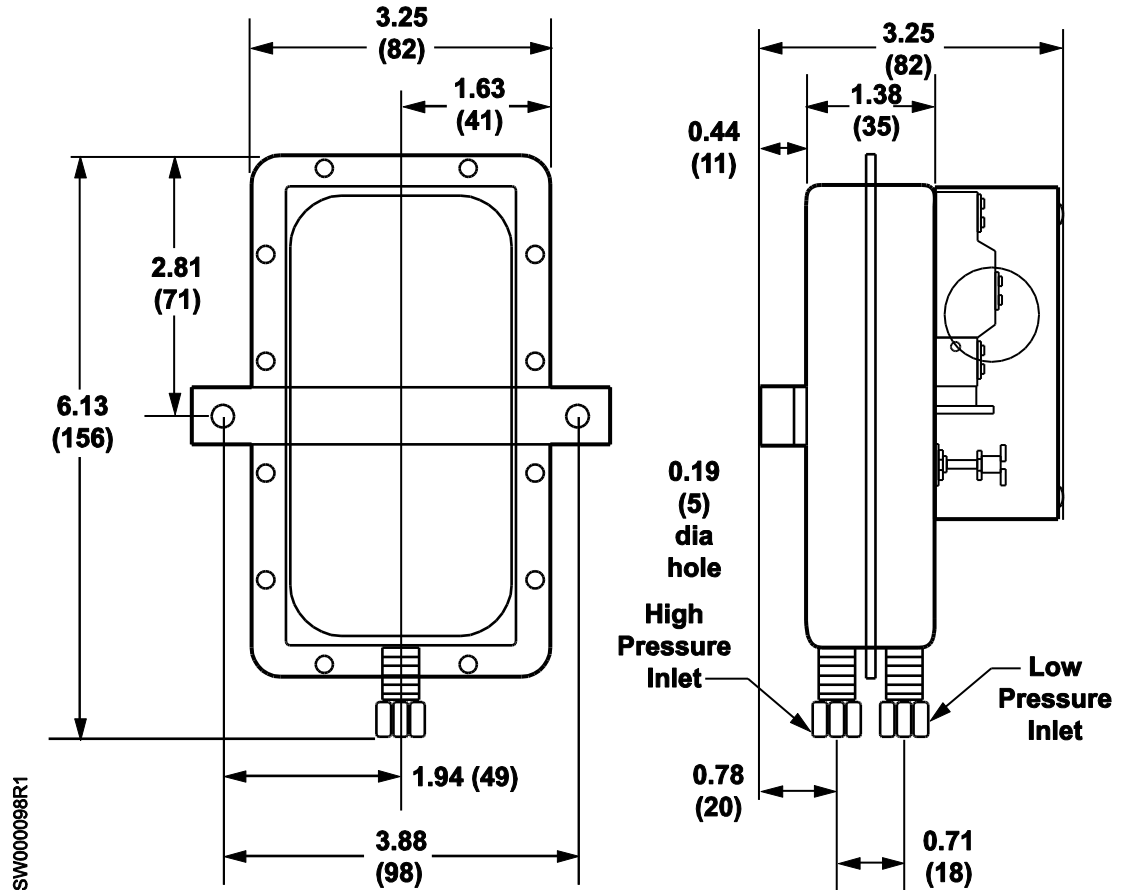

Figure 9. Dimensions in Inches (Millimeters).

Information in this publication is based on current specifications. The company reserves the right to make changes in specifications and models as design improvements are introduced. Powers is a registered trademark of Siemens Industry, Inc. Other product or company names mentioned herein may be the trademarks of their respective owners. © 2024 Siemens Industry, Inc.